

# Multilayer Chip High Frequency Bead Array

## BEAD ARRAY SERIES

# PRODUCT CATALOG



寶仁弘電子有限公司 Prosperity Electronic Co., Limited

EML: brh@baorenhong.com Web: www.baorenhong.com

TEL: 0755-29687188 FAX: 0755-29688152

深圳市寶安區福永鎮立新二路天佑創客產業園

TEL: 0512-36878535 FAX: 0512-36878435

江蘇省昆山市花橋鎮綠地大道1325號

# Multilayer Chip High Frequency Bead Array

## ◎ Product introduction 產品介紹

- Excellent solderability and heat resistance for either flow or reflow soldering

良好的可焊性和耐焊性

- By the use of 3-4 chip, it can be very effective in using high density circuit design of the interference suppression.

利用由3-4個芯片，它可以非常有效地採用高密度來抑制電路設計中的干擾。

- Crosstalk between adjacent circuits are minimized

回路間無串擾

- On the condition of low frequency loss is less, the impedance can be rapidly corresponding to high frequency type

在低頻下損失較少，阻抗可急速增加的高頻對應型



## ◎ Product application 產品應用

- Computer and peripheral equipment, DVD, camera, and other office equipment noise suppression.

電腦及周邊設備，DVD，照相機，辦公設備等雜訊抑制

## ◎ Product Identification 產品標識

MULT 2010 S 121 A 03 T

MULT-----Series name 系列名稱

2010-----Dimension 產品尺寸

S-----Material code 材料代碼

121-----Impedance 阻抗值【120=12Ω · 121=120Ω · 122=1200Ω】

A-----High current 耐大電流

03-----Current value 電流值

T-----Taping 編帶盤裝

# Multilayer Chip High Frequency Bead Array

## ◎Shape&Dimensions 形狀與尺寸:

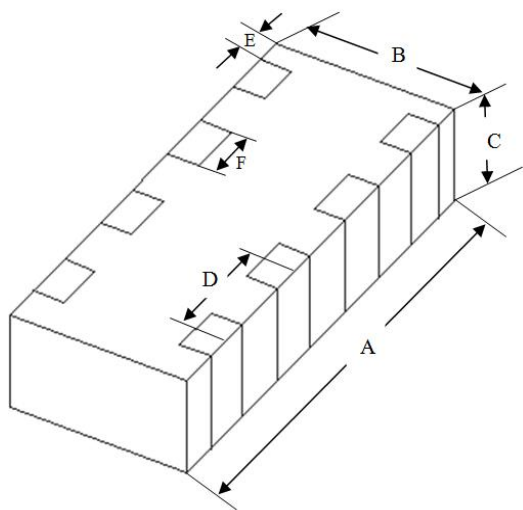

UNIT: mm

PART NUMBE	A	B	C	D	E	F	CHIPS REEL
2010	2.0±0.2	1.0±0.2	0.55±0.1	0.5±0.1	0.25±0.2	0.25±0.2	4K
3216	3.0±0.2	1.6±0.2	0.8±0.2	0.8±0.2	0.2±0.1	0.4±0.2	3K

## ◎Recommender Land Pattern 推薦焊盤布局:

UNIT: mm

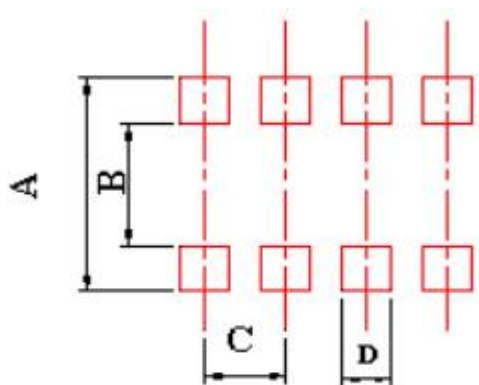

PART NUMBE	A	B	C	D
2010	1.25	0.25	0.5	0.3
3216	2.1	1.2	0.8	0.4

# Multilayer Chip High Frequency Bead Array

## ◎ Detailed specifications and parameters are introduced

### 詳細規格及參數介紹

ORDERING CORE	Impedance ( $\Omega$ )	Test Frequency (MHz)	DC Resistance ( $\Omega$ )MAX	Rated Current (mA)MAX
MULT2010S121A03T	120 $\pm$ 25%	100	0.300	300
MULT2010S301A02T	300 $\pm$ 25%	100	0.600	200
MULT2010H260A03T	26 $\pm$ 25%	100	0.300	300
MULT2010H600A03T	60 $\pm$ 25%	100	0.400	300
MULT2010H101A02T	100 $\pm$ 25%	100	0.550	200
MULT2010H151A02T	150 $\pm$ 25%	100	0.550	200
MULT2010H221A02T	220 $\pm$ 25%	100	0.600	200
MULT2010H301A02T	300 $\pm$ 25%	100	0.650	200

#### Standard Testing Condition:

Temperature: Ordinary Temperature(15 to 35°C), In case of doubt: 20 $\pm$ 2°C

Humidity: Ordinary Humidity(25 to 75% RH), In case of doubt: 60 to 70 % RH

The product shall be used within 3 months of the day of manufacture.

More than this time should check the reliability of the product.

# Multilayer Chip High Frequency Bead Array

## ◎ Detailed specifications and parameters are introduced

詳細規格及參數介紹

### Standard Type:

ORDERING CORE	Impedance ( $\Omega$ )	Test Frequency (MHz)	DC Resistance ( $\Omega$ )MAX	Rated Current (mA)MAX
MULT3216S300T	30 $\pm$ 25%	100	0.100	200
MULT3216S600T	60 $\pm$ 25%	100	0.300	300
MULT3216S900T	90 $\pm$ 25%	100	0.250	200
MULT3216S121T	120 $\pm$ 25%	100	0.300	200
MULT3216S151T	150 $\pm$ 25%	100	0.300	200
MULT3216S221T	220 $\pm$ 25%	100	0.400	200
MULT3216S301T	300 $\pm$ 25%	100	0.500	200
MULT3216S331T	330 $\pm$ 25%	100	0.500	200
MULT3216S601T	600 $\pm$ 25%	100	0.600	200
MULT3216S102T	1000 $\pm$ 25%	100	0.900	100

### Standard Testing Condition:

Temperature: Ordinary Temperature(15 to 35°C), In case of doubt: 20 $\pm$ 2°C

Humidity: Ordinary Humidity(25 to 75% RH), In case of doubt: 60 to 70 % RH

The product shall be used within 3 months of the

More than this time should check the reliability c

# Multilayer Chip High Frequency Bead Array

◎ Detailed specifications and parameters are introduced

詳細規格及參數介紹

**High Frequency Type:**

ORDERING CORE	Impedance	Test Frequency	DC Resistance	Rated Current
	( $\Omega$ )	(MHz)	( $\Omega$ )MAX	(mA)MAX
MULT3216H350T	35 $\pm$ 25%	100	0.300	300
MULT3216H600T	60 $\pm$ 25%	100	0.300	300
MULT3216H800T	80 $\pm$ 25%	100	0.250	200
MULT3216H101T	100 $\pm$ 25%	100	0.300	200
MULT3216H121T	120 $\pm$ 25%	100	0.300	200
MULT3216H151T	150 $\pm$ 25%	100	0.400	200
MULT3216H201T	200 $\pm$ 25%	100	0.300	150
MULT3216H221T	220 $\pm$ 25%	100	0.450	200
MULT3216H301T	300 $\pm$ 25%	100	0.500	200
MULT3216H601T	600 $\pm$ 25%	100	0.650	200
MULT3216H102T	1000 $\pm$ 25%	100	0.900	100

Standard Testing Condition:

Temperature: Ordinary Temperature(15 to 35°C), In case of doubt: 20 $\pm$ 2°C

Humidity: Ordinary Humidity(25 to 75% RH), In case of doubt: 60 to 70 % RH

The product shall be used within 3 months of the day of manufacture.

More than this time should check the reliability of the product.

# Multilayer Chip High Frequency Bead Array

◎ Test curve of reference as follows

測試曲線參考如下：

— Z — R — XL

MULT2010S121A03T

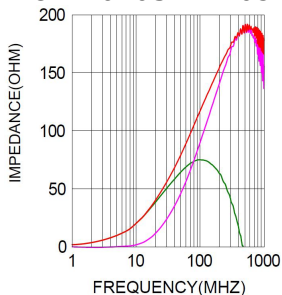

MULT2010S301A02T

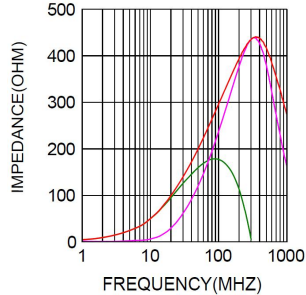

MULT2010H260A03T

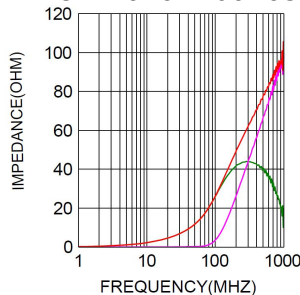

MULT2010H600A03

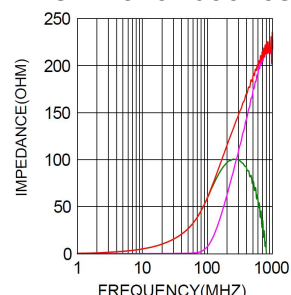

MULT2010H101A02T

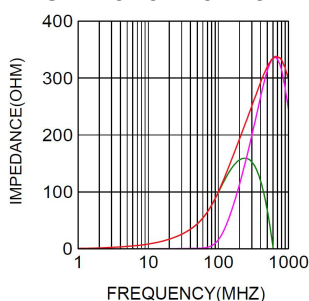

MULT2010H151A02T

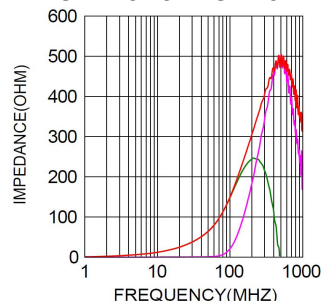

MULT2010H221A02T

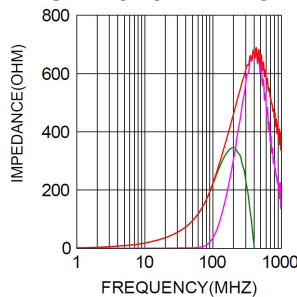

MULT2010H301A02T

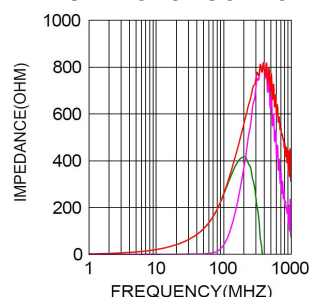

# Multilayer Chip High Frequency Bead Array

◎ Test curve of reference as follows

測試曲線參考如下：

— Z — R — XL

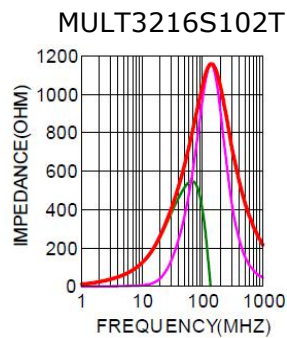
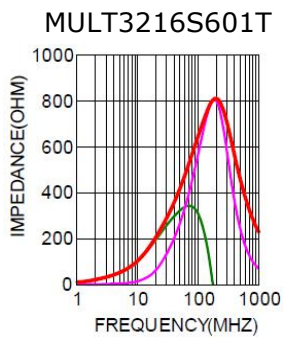
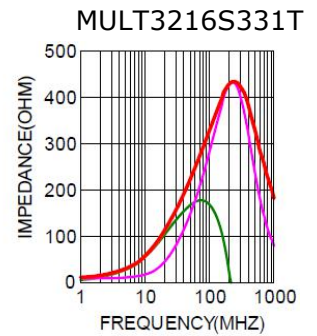
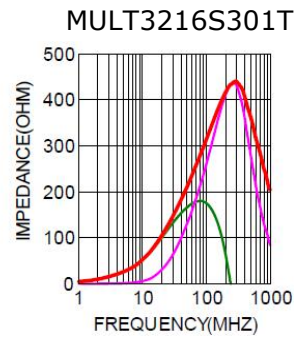
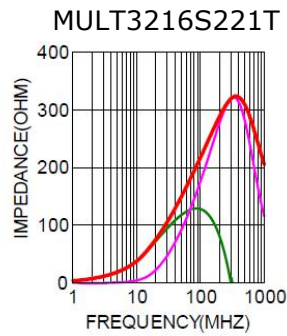
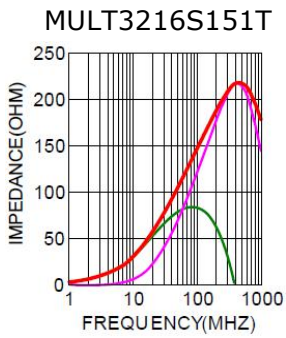
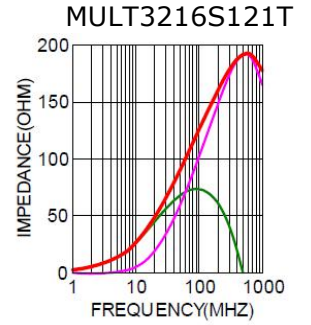
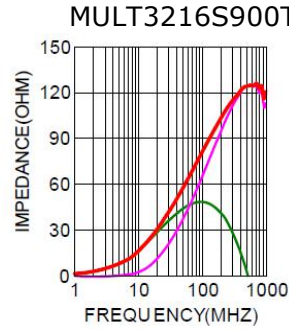
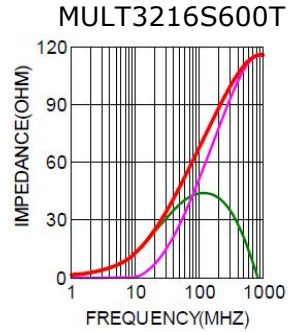
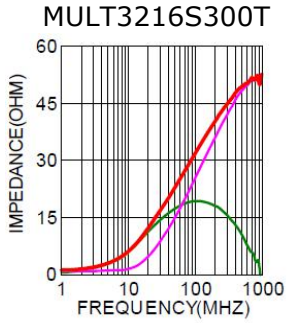



# Multilayer Chip High Frequency Bead Array

◎ Test curve of reference as follows

測試曲線參考如下：

— Z — R — XL

